

CITY CAB

CANTER 516

DUONIC AMT

ADVANCED
SAFETY
SYSTEMS



GVM:
4,983kg



Power / Torque:
110kW / 370Nm



Wheelbase:
2,800mm (C)

- Electronic Brake System **NEW**
- Electronic Stability Control **NEW**
- Active Emergency Braking System **NEW**
- Lane Departure Warning System **NEW**
- 5yr/200,000km warranty **NEW**
- 30,000km service intervals

SPECIFICATIONS - CANTER 516 CITY CAB

MODEL

4x2 516 CITY CAB 6 SP. AMT FEA21CR3SFBC

WHEELBASE (mm)

2,800 (C)

GVM (kg)

4,983

GCM (kg)

8,483

ENGINE

Engine Version	FUSO 4P10-T4 Euro 5 Diesel
Configuration	4 Cyl. In-line DOHC, 4-Valve
Type	Variable Geometry Turbo Charged Air to Air Intercooled
Displacement	3 litre (2998cc)
Power (DIN)	110kW @ 2840~3500rpm
Torque (DIN)	370Nm @ 1350~2840rpm
Maximum Engine Speed (rpm)	4100
Compression Ratio	17.5:1
Cooling System / Oil Cooler	Water cooled with Viscous fan, 13.0L capacity. Engine oil cooler
Air Cleaner	Paper Element Type with Restrictor Indicator. Vertical Intake Mounted on Clean Air Side (RH)
Emission Control	Diesel Particulate Filter (DPF) Exhaust Dash Display DPF Status 0~9 (Empty~Full) Parked Regeneration possible from 7~9
Emission Level	EURO 5 (ADR 80/03) and EEV rated (Enhanced Environmentally-Friendly Vehicle)

4P10-T4

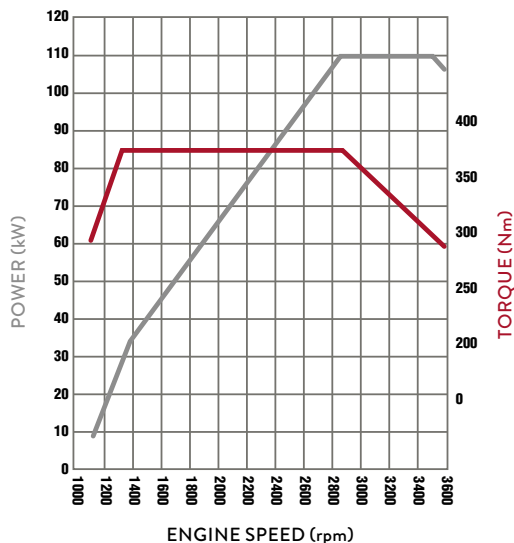

FUEL

Injection System	Bosch Common Rail Direct Injection Bosch Piezo Technology Injectors
Tank Type	Rectangular Steel Tank with Locking Cap
Fuel Capacity (L)	100
Filtration	Filter with Water Separator and Indicator Sensor

ELECTRICAL

Voltage	12V Negative Earth
Alternator Capacity	12V-110 amp
Battery Specification	Heavy Duty 115D31L x 2
Headlamp Type (W)	Halogen 2 x 55/60
Fog lamp in bumper	Standard

CLUTCH

Clutch Model	DUONIC Automated Manual (no clutch pedal)
Type	Dual Clutch (Wet Multi-plate)

TRANSMISSION

Version	FUSO DUONIC M038S6
Type/Speeds	6 Speed Automated Manual with Auto and Manual Modes
Features	Virtually Instant Gear Changes In-Dash Gear Lever with Park Brake Position ECO Mode to Minimise Fuel Usage
Ratios	1st: 5.397 2nd: 3.788 3rd: 2.310 4th: 1.474 5th: 1.000 6th: 0.701 Rev. 5.397
PTO Opening	LH Side

FRONT AXLE

Axle	FUSO F200T Independent Front Suspension Type
Design Capacity (kg)	2,300
Max Operating Capacity (kg)	2,180

FRONT SUSPENSION

Type	Double Wishbone Independent Front Suspension with Coil Springs and Shock Absorbers
------	--

REAR AXLE

Axle	FUSO D03 Full Floating Banjo Type
Ratio	4.444:1
Design Capacity (kg)	3,800
Max Operating Capacity (kg)	3,800

REAR SUSPENSION

Type	Steel Suspension
Details	Taper Leaf Spring with Stabiliser Bar and Double Acting Shock Absorbers
Size Main Leaves (mm)	1,100 x 70

STEERING

Power Assisted	Tilt/Telescopic Adjustable Steering Wheel
----------------	---

BRAKES

Type	Hydraulic Dual Circuit with Front and Rear Single Caliper Discs
Size Front / Rear (mm)	276 x 28
Features	ABS + EBD + EBS Exhaust Brake Brake Priority System
Park Brake	Transmission Mounted

SPECIFICATIONS - CANTER 516 CITY CAB

ADVANCED
SAFETY
SYSTEMS

WHEELS AND TYRES

Wheel Size	16.0x5.5K-115
Tyre Size All	185/85R16
Spare Tyre Carrier	Yes

CHASSIS

Size (mm)	188 x 60 x 4
-----------	--------------

Refer to the bodybuilders guidelines on the Fuso website (www.fuso.co.nz) before mounting a body or modifying the chassis

INSTRUMENTS

Gauges	Speedometer with Odometer; Tachometer; Fuel Level; Water Temperature
Colour Information Display	Fuel Consumption DPF Bar Chart from 1~9 Water Temperature Maintenance Reminder System Tripmeters

STANDARD FEATURES

Cab Cooling and Heating	Air Conditioner / Heater / Demister
Accessory Power	12V Accessory Power Outlet / Cigar Lighter
Driving	Keyless Central Locking Electric Windows
Storage	Dual Overhead Storage Pockets In-Dash Centre Document Storage Door Storage Pockets Lockable Glove Box

CAB FEATURES

Type	All Steel Forward Control Manual Tilt
Mounting	Hydroelastic 4 Point
Colour	Natural White (W31)
Interior	Fully Trimmed cab with vinyl floor covering
Seating Capacity	3
Seat (driver)	Heavy Duty with LH Arm Rest Adjustable Lumbar Support
Seats (passenger)	Flat Folding, 2 Passenger Bench

SERVICE INTERVALS

30,000km full service / 15,000km safety inspection
30,000km full service intervals, depending on application/use.
15,000km safety inspection, with greasing, required to maintain warranty cover and ensure optimum performance.

WARRANTY

5 years / 200,000km **NEW**
Simply have your vehicle serviced at an authorised FUSO Service Centre, at the recommended servicing intervals, and you are covered by an additional 2 year/100,000km FUSO warranty on top of the first 3 years/100,000km. That's a total of 5 years/200,000km cover.
Refer to terms and conditions in the FUSO warranty booklet for full details.

SAFETY FEATURES

ACTIVE SAFETY FEATURES

Electronic Brake System (EBS)	Yes	NEW
Electronic Stability Control (ESC)	Yes	NEW
Active Emergency Braking System (AEBS)	Yes	NEW
Lane Departure Warning System (LDWS)	Yes	NEW

CAB

Structure	ECE R-29 Reinforced Cab Side Intrusion Bar	
Airbags	Driver's (steering wheel) Passenger's (dashboard)	NEW
Seatbelts	ELR 3-Point (+ height-adjustable with pre tensioner for driver) Lap Belt (centre passenger)	
Steering Wheel	Energy-absorbing Adjustable (height and reach)	
Rearview Mirrors	Heated	
Fog Lamps	Yes	
Front Step Lights	Yes	
Keyless Central Locking	Yes	
7" Touchscreen Media Unit	AM/FM/DAB + USB + AUX Apple CarPlay and Android Auto Wi-Fi enabled for Internet Radio Bluetooth 32GB capacity storage HD Reverse Camera included †	NEW

CHASSIS

Speed Limiter	Yes (activated and adjustable by FUSO dealer)	
Anti-Lock Braking System (ABS)	Yes	
Anti-Slip Regulator (ASR)	Yes	
Electronic Brake Force Distribution (EBD)	Yes	
Disc Brakes	Auto-Adjusting, 4 Wheel Single Caliper	
Brake Priority System	Yes	
Exhaust Brake	Yes	
Hill Start Assist	Yes	
Reverse Warning Buzzer	Yes	
Anti Roll Bar	Yes	
Brake Wear Indicator	Yes	

OPTIONS

† Additional Multimedia Display Cameras (up to 4)
Truck Specific GPS Navigation
Reversing Sensors
Tyre Pressure Monitoring System
Wireless Phone Charge Pocket

KERB WEIGHTS AND MAX AXLE LOADS (kg)

Model		Vehicle Ratings**		Max Axle Loadings**		Kerb Weights*		
		GVM	GCM	Front	Rear	Front	Rear	Total
4x2 516 City Cab 6 Sp. AMT	FEA21CR3SFBC	4,983	8,483	2,180	3,800	1,380	570	1,950

* Weights (est.) includes 10L fuel and spare wheel and are subject to 2.5% variation (+/-)

** Vehicle ratings and max axle loadings may be limited by local regulations.

SPECIFICATIONS - CANTER 516 CITY CAB

PERFORMANCE

Turning Circle (kerb to kerb - metres)	9.8
Road Speed (km/h) at Max Engine Speed	144
Engine Speed (rpm) at 90km/hr (top gear)	2100
Gradeability at Rated GVM (theoretical)*	41%
Notes	*This is theoretical performance only. Actual performance may vary under different conditions

DIMENSIONS (mm)

Wheelbase	2,800
Length Overall	4,985
Height Overall	2,110
Width Overall	1,865
Width Rear Axle	1,865
Width Front Track	1,390
Width Rear Track	1,435
Width Frame	700
Height Frame at Rear Axle	733

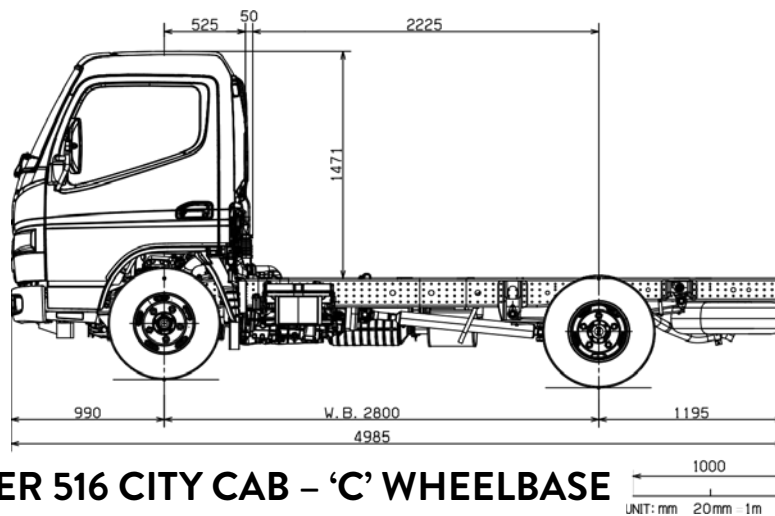

Scale = 1:50 (20mm = 1 metre). This scale is accurate when used on the original spec sheet, be aware that enlarging these illustrations can alter the scale and cause incorrect measurements. Fuso New Zealand and its authorised dealers always recommend customers seek professional advice from independent sources before commencing any engineering activities.

A policy of continual improvement means that specifications detailed in this brochure are subject to change without notice. Contact your authorised Fuso dealer to confirm current specifications. Fuso is a registered trademark of Mitsubishi Fuso Truck & Bus Corporation. Copyright © Fuso NZ (2021)